

Air Conditioning (A/C) Pressure Relief Valve

Material

Item	Specification
Motorcraft® PAG Refrigerant Compressor Oil YN-12-D	WSH-M1C231-B

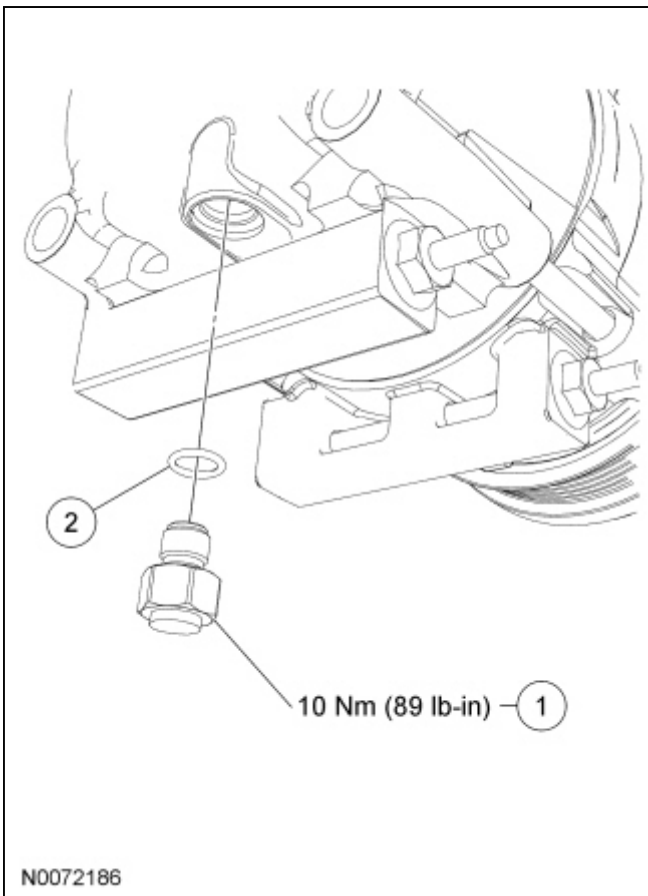

Item	Part Number	Description
1	19D644	A/C compressor pressure relief valve
2	—	O-ring seal (part of 19D644)

Removal and Installation

Vehicles with 4.6L or 5.4L

1. With the vehicle in NEUTRAL, position it on a hoist. For additional information, refer to [Section 100-02](#).

All vehicles

2. Recover the refrigerant. For additional information, refer to [Section 412-00](#).
3. Remove the A/C compressor pressure relief valve and O-ring seal.
 - To install, tighten to 10 Nm (89 lb-in).

4. **NOTE:** A new O-ring seal will already be installed on the new A/C pressure relief valve service part.

To install, reverse the removal procedure.

- Lubricate the refrigerant system with the correct amount of clean PAG oil. For additional information, refer to [Section 412-00](#).

5. Evacuate, leak test and charge the refrigerant system. For additional information, refer to [Section 412-00](#).
-